

MESA TERA

M □ B L E B ◯

## DESGLOSE DE PIEZAS

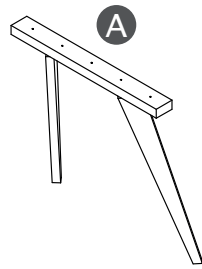

PATAS  
X2



TORNILLOS x 10

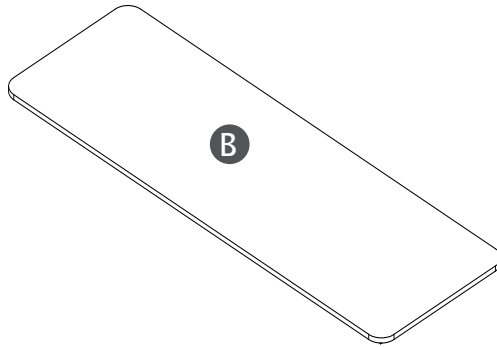

TABLERO  
X1

## MONTAJE DE LA MESA hasta 2 m

- 1 Visualización de la posición de las piezas.

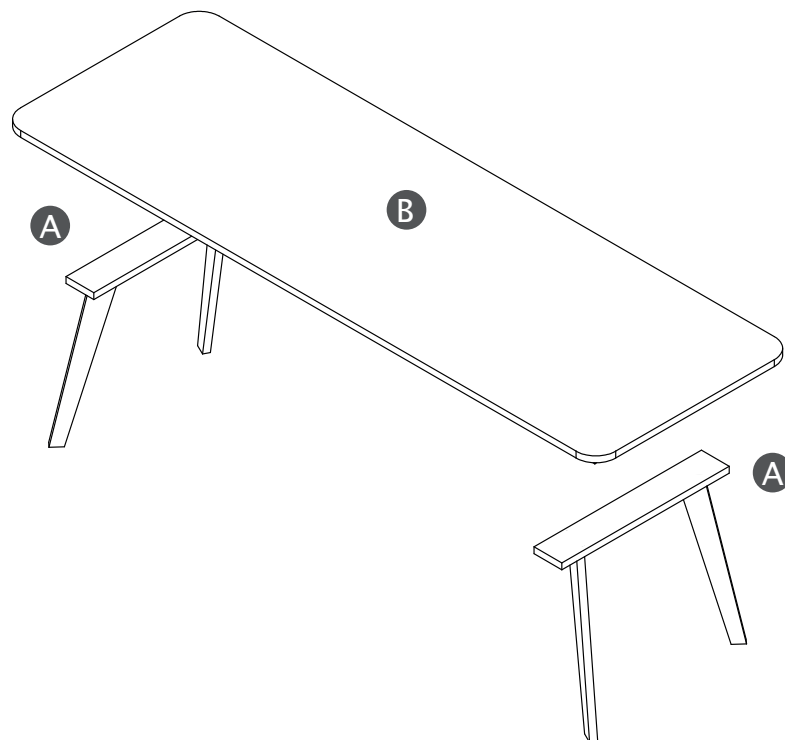

2 Atornillar las patas al tablero y a continuación girar la mesa.

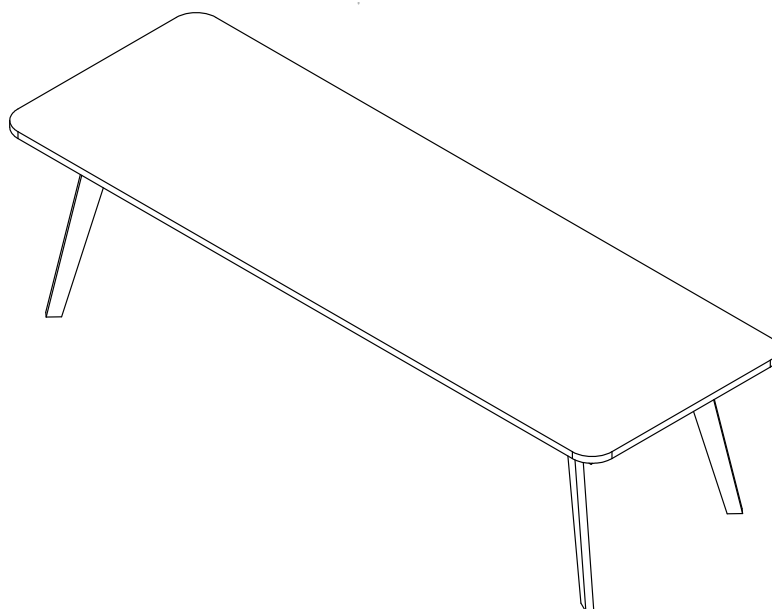
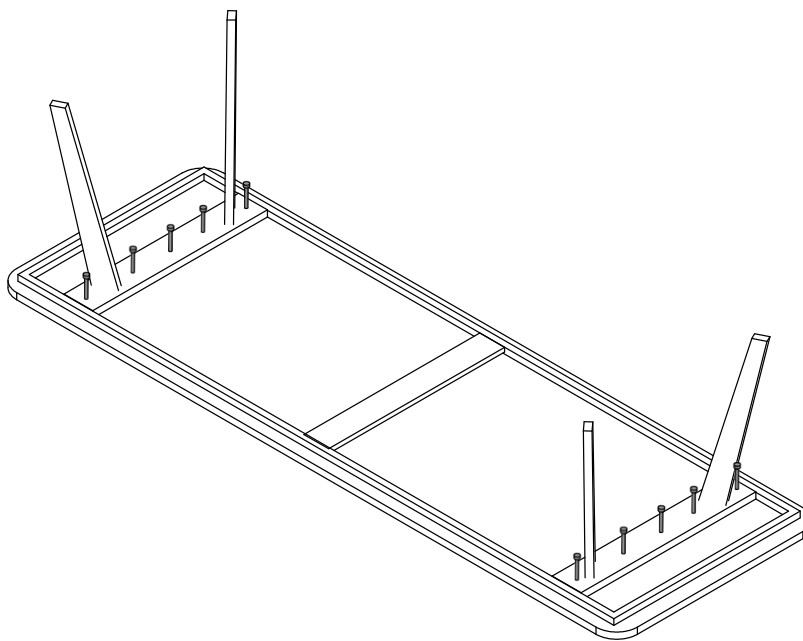

## DESGLOSE DE PIEZAS

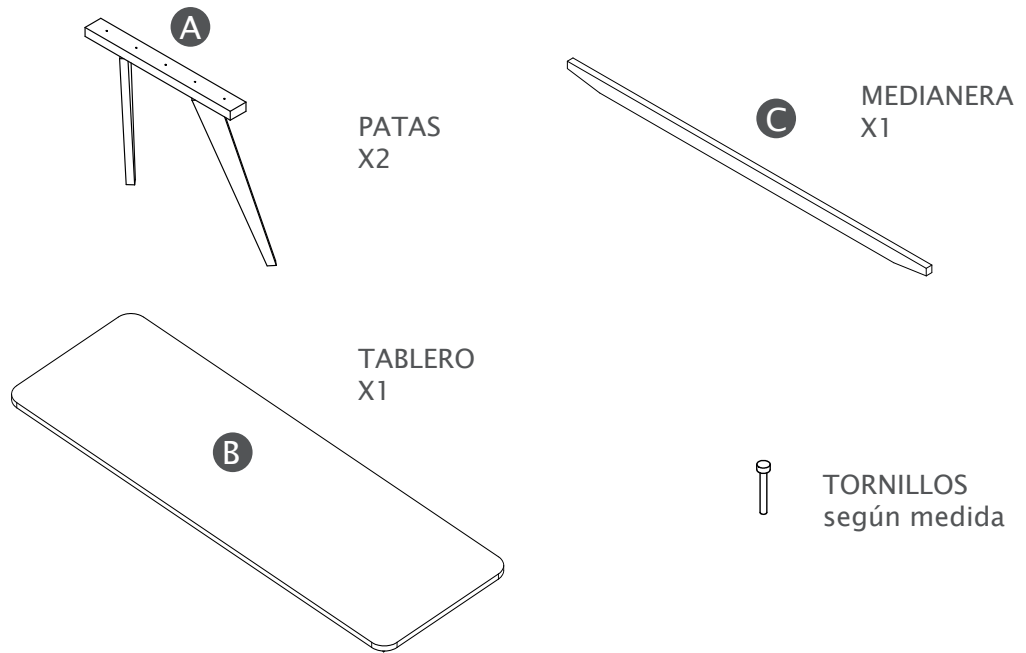

## MONTAJE DE LA MESA más de 2 m

- 1 Visualización de la posición de las piezas.

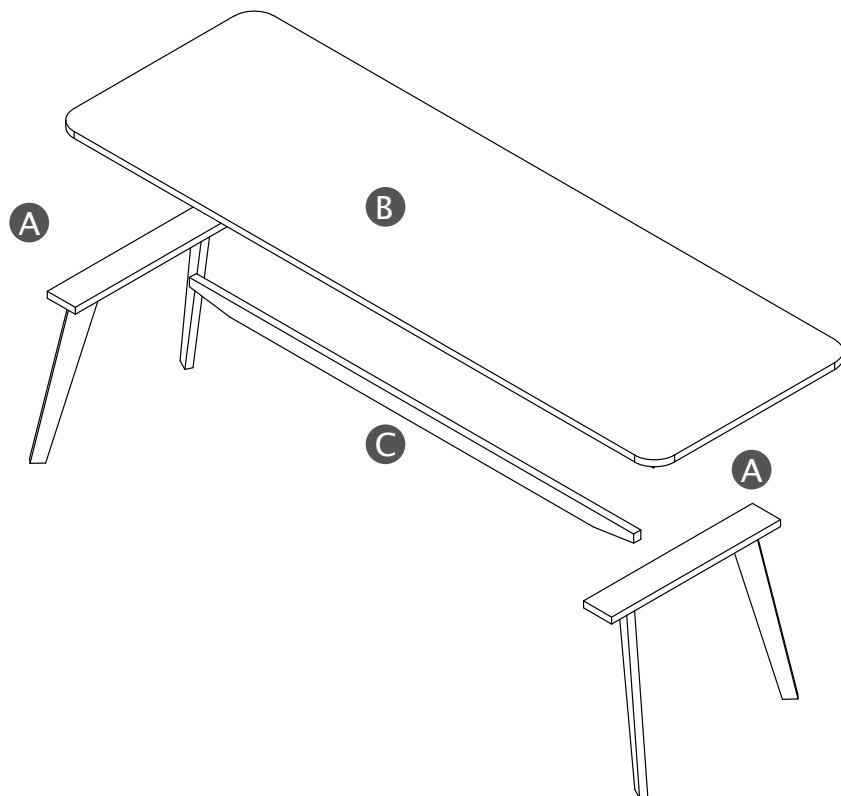

- 2 Atornillar las patas a la pieza central, creando un cuerpo.

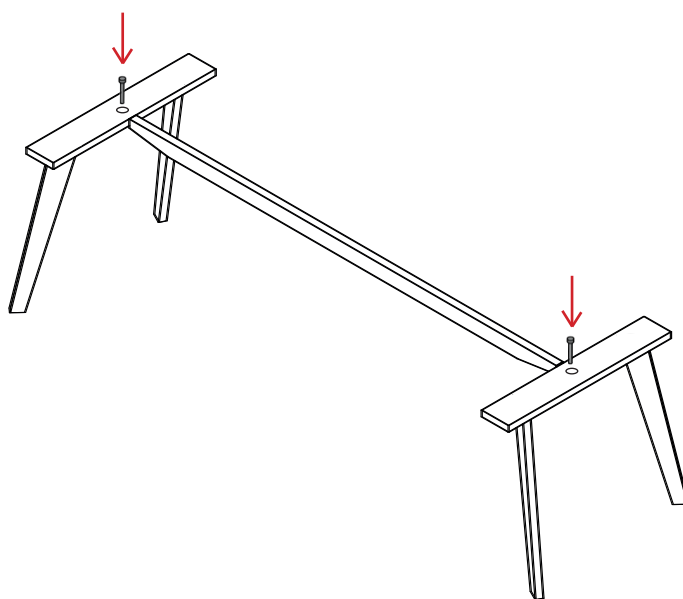

- 3 Atornillar el cuerpo creado y a continuación girar la mesa.

